

Pressure Transmitter for General Industries

SE700 series



Ideal for Accurate Measurement

- Pressure sensor developed for industrial use
- Wide applications for hydraulic, pneumatic, corrosive & inert gases
- Wide pressure range from ultra low pressure through high pressure
- Compact and smart size

Contact to hello@tem-tech.co.jp

Tem-Tech Lab.

SE700 series

2003.9

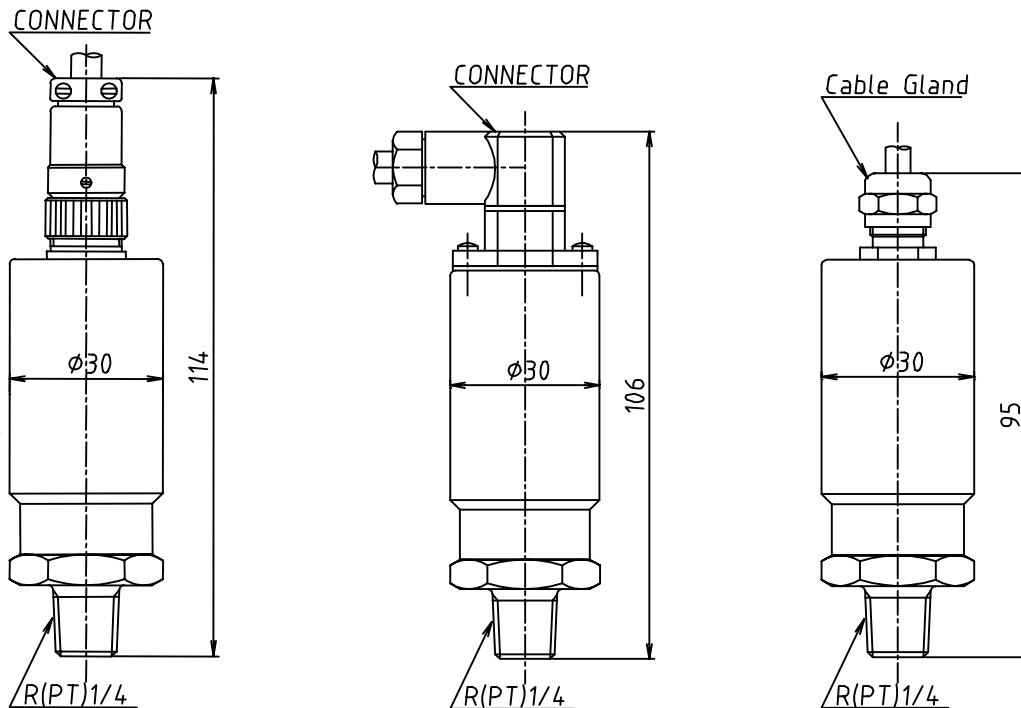

SE700H-xxx-SMR1T (Indoor)

SE700H-xxx-SMR1H (Outdoor)

SE700HP-xxx-SMR1P

Application	Oil, Gas and Other chemical fluids, which are compatible with the wetted material (Applicable for outdoor using)	
Measurement Range	0(-14.7) to 3000psi (Gauge, Compound pressure, To be specified for other ranges)	
Proof Pressure	2 × F.S. for ranges from 0 to 250psi, 1.5 × F.S. for ranges from 251 to 3000psi	
L.H.R.*1	±0.5%F.S	
Output Signal	4-20mA (420)	0-5V (005), 1-5V (105), 0-10V (010)
Supply Voltage	DC24V	DC15V – 24V
Operating Temp Range	0 to 80°C	
Compensated Temp Range	0 to 60°C	
Thermal Effects	± 0.1% F.S/°C	
Wetted Parts	Diaphragm SUS316L	
Seal Method	Electron Beam Welding	
Leak Rate	<3 × 10 ⁻⁸ Pam ³ /sec	
Process Connector	PT, PF, Swagelock, VCR	
Electrical Connector	Tajimi (T), Pig tail(P), Water tight box(B), DIN water tight connector(H)	
Fitting Size	1/4" (1), 3/8" (2), 1/2" (3)	

Note*1 Linearity, Hysteresis, Repeatability

Specifications are subject to change without notice

***Ordering Information (Example: SE700H-420-SMR1T)**

SE	Type	Output	Type	Fitting	Fitting	Fitting Size	Connector
700H	Machined Body	420 : 4-20mA	S : Single Ended	M : Male	R : PT	1 : 1/4"	T : Tajimi
700T	Welded Body	005 : 0-5V	T : Flow Through	F : Female	G : PF	2 : 3/8"	P : Pigtail
		105 : 1-5V		Z : Others	S : Swagelock	3 : 1/2"	B : Water tight box
		010 : 0-10V			V : VCR		H : DIN water tight connector

Contact to hello@tem-tech.co.jp